

Exploded View

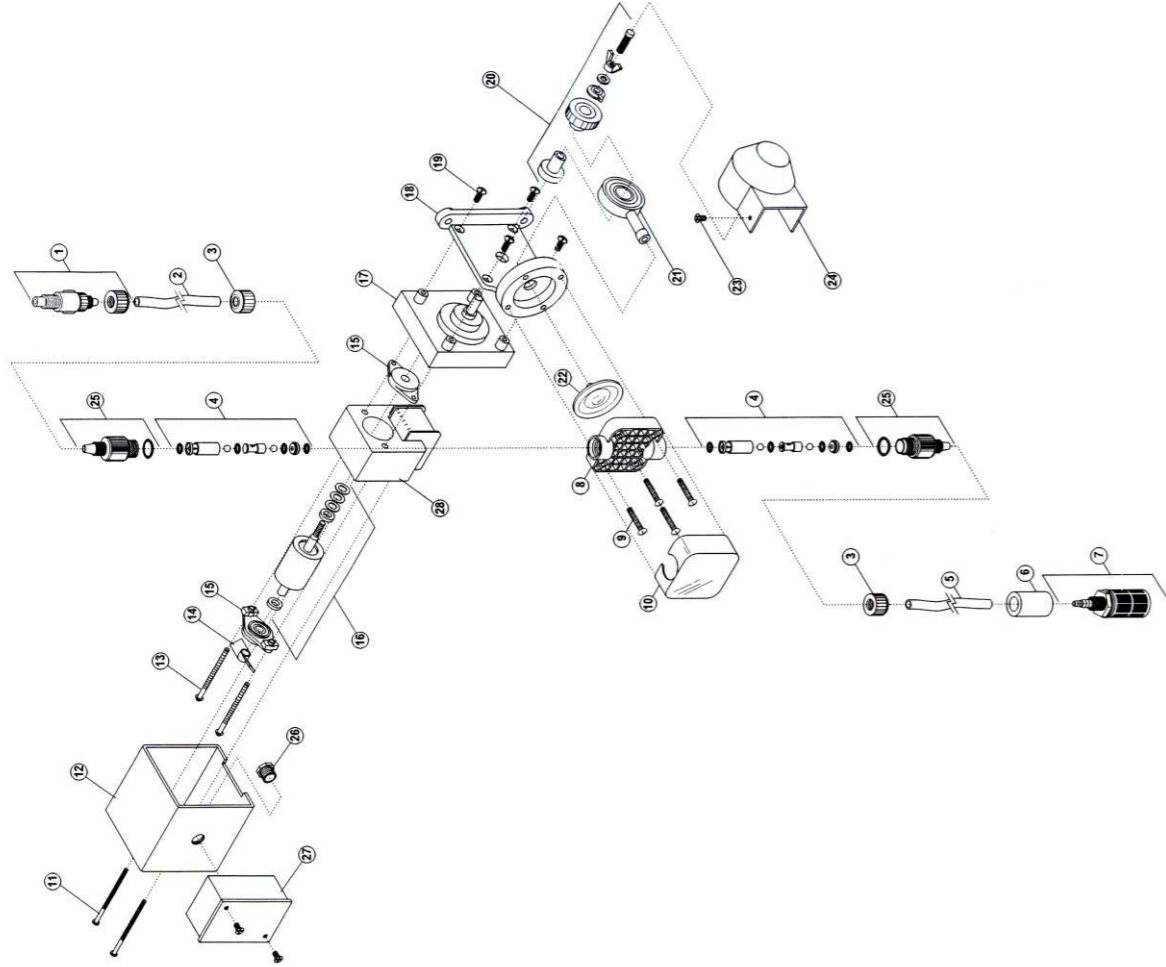

M-600 Parts List

No.	Catalog No.	Description	Amount	Reqd.
1	M-395-6V	Injection/anti-syphonvalve6 PSI, Viton	1	1
	M-395-6E	Injection/anti-syphonvalve6 PSI, EP(optional)	1	1
2	M-335-6	Discharge Tubing3/8OD, 5ft. OpaquePoly-E	1	1
3	M-330-6	Tube nut	2	2
	M-568V-4	Bullet valve (doubleball), Viton,4 pack set	2	2
4	M-568V-10	Bullet valve (doubleball), Viton,10 pack set	2	2
	M-569E-4	Bullet valve (doubleball), EP,4 pack set (optional)	2	2
	M-569-10	Bullet valve (doubleball), EP,10pack set (optional)	2	2
5	M-334-6	Suctiontubing3/8"OD, 5ft. Clear PVC w/indicator	1	1
6	M-346	Ceramic weight	1	1
7	M-345V	Footvalve/strainerPoly-Pro, Viton	1	1
	M-345E	Footvalve/strainerPoly-Pro, EP(optional)	1	1
8	M-535	Heavy duty molded pump head	1	1
9	M-504HD	Screw, HDPump head 10-32x1-1/4"	4	4
10	M-535FC	Pump head cover:Chem Feed logo	1	1
11	M-628	Cover Screw 6-32x2 -3/4" Steel	2	2
12	M-608P	Motor Cover	1	1
13	M-625	Motor screw 8 -32 x 2 -1/2"	2	2
14	M-612F	Rotor Fan	1	1
15	M-612P	Rotor Bearing	2	2
16	M-616PN	Rotor w/ Spacers	1	1
	M-618P-14	Gearbox Assembly, 14 RPM	1	1
	M-618P-30	Gearbox Assembly, 30 RPM	1	1
17	M-618P-45	Gearbox Assembly, 45 RPM	1	1
	M-618P-60	Gearbox Assembly, 60 RPM	1	1
	M-618P-125	Gearbox Assembly, 125 RPM	1	1
	M-618P-250	Gearbox Assembly, 250 RPM	1	1
18	M-301	Motor Mount	1	1
19	M-624	Motor Mount Screw 10 -32x1/2"	4	4
20	M-325	Cam S/AM-600	1	1
21	M-304	Yokew/Bearing	1	1
22	M-406T	Diaphragm Tefloncoated, EP	1	1
23	90011-155	Screw 6-32x3/8"	1	1
24	90002-201	Cam COVER	1	1
25	M-560-6V	Bullet ValveAdapter,VitonO-ring	2	2
	M-560-6E	Bullet ValveAdapter,EP O-ring	2	2
26	90007-5151/2"	Aluminum Chase Nipple	1	1
27	M-308J	Junction Box Complete w/Coverand Gasket	1	1
	M-615P-1	Stator S/A115V /60Hz, blue-black (leadwires)	1	1
	M-615P-2	Stator S/A230V /60Hz, red-black (leadwires)	1	1
	M-615P-3	Stator S/A220V 50Hz, brown-blue (leadwires)	1	1
	M-615P-4	Stator S/A24V 60Hz, blue-white (leadwires)	1	1
	M-615P-6	Stator S/A230V /60Hz, red-yellow (leadwires)	1	1
	M-615P-8	Stator S/A220V 50Hz, brown-yellow (leadwires)	1	1
	M-615P-9	Stator S/A115V /60Hz, blue-yellow (leadwires)	1	1



# DOSING PUMP

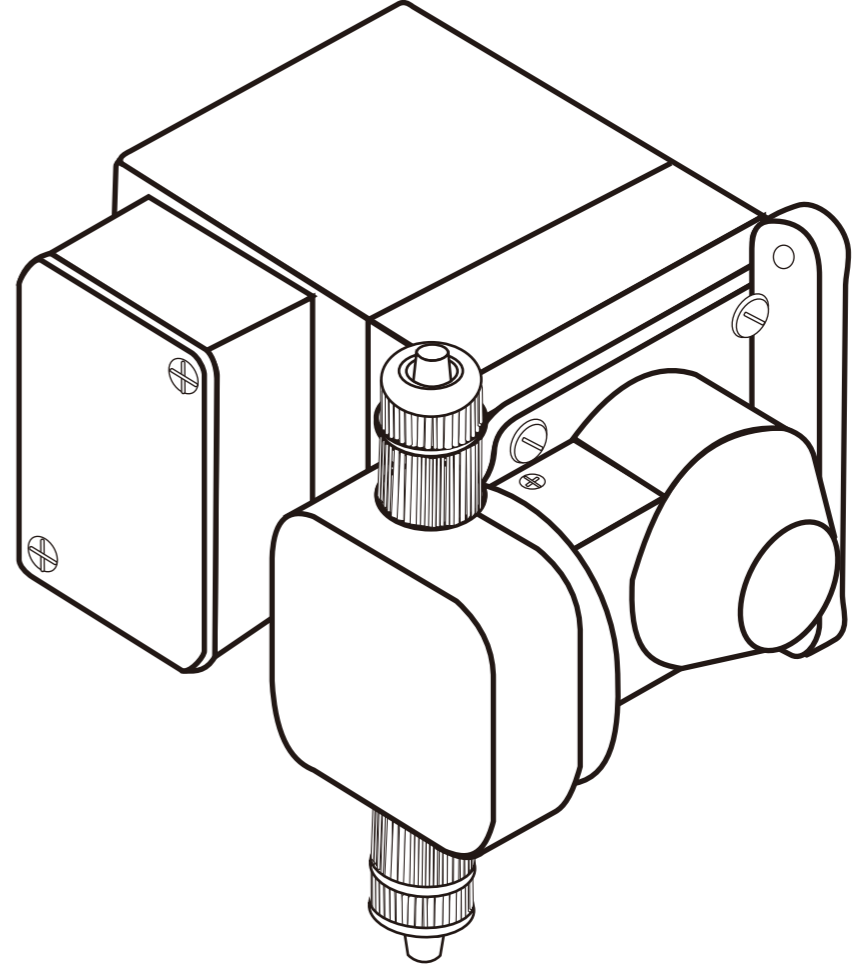

## Introduction

Thank you for purchasing the M-600P positive displacement metering pump. The M-600 is designed to inject chemicals into piping systems. All models are equipped with a top mounted mechanical flow rate adjustment knob. Optional on/off cycling timers are available.

M600					
Model Number	Maximum GPD	Maximum GPH	Maximum LPH	Maximum PSI	Strokes Per Minute
M-614P	24	1.0	3.8	125	14
M-630P	58	2.4	9.3	125	30
M-645P	91	3.8	14.9	80	45
M-660P	110	4.6	17.4	60	60
M-6125P	237	9.9	37.0	30	125
M-6250P	389	16.2	61.4	10	250

Standard components / materials:  
 • Diaphragm material is: Teflon with EP (Ethylene-Propylene) backing, wetted material is Teflon.  
 • Pumphead material is: Polypropylene  
 • O-ring material is: EP (Ethylene-Propylene)

## Specifications

Maximum Working Pressure	125psig/ 8.6bar*
Maximum Fluid Temperature	130°F /54°C
Output Accuracy	+/- 10% of maximum (water@70°F, 0 psig, and 5' suction lift)
Ambient Temperature Range	14 to 110°F/-10 to 43°C
Enclosure	Zinc Metal
Duty Cycle	Continuous
Maximum Viscosity	1,000 Centipoise
Maximum Suction Lift	up to 10ft. water
Power Requirements	115V60Hz 45 Watts 220V50Hz 45 Watts 230V60Hz 45 Watts 24V60Hz 45 Watts
Dimensions	6-1/2" high x 6-1/2" wide x 5-3/4" deep
Weight	8 lb.

## M-600 Features

- Double-ball ceramic check valves.
- PVDF (Kynar) valve assemblies.
- Viton o-rings.
- High outlet pressure capability of 125 PSIG.\*
- Easy access, side mounted mechanical feed rate adjustment.
- Ball bearing supported motor drive shaft.
- Permanently lubricated ball bearing motor.
- 27:1 adjustment turn down ratio.
- Easy servicing.
- Includes suction tube foot valve & strainer, suction tube weight, suction tubing, discharge tubing and injection fitting with internal back-flow check valve and mounting hardware.

\* Most models.

## How To Install the M-600

**CAUTION: PROPER EYE AND SKIN PROTECTION MUST BE WORN WHEN INSTALLING AND SERVICING THE M-600**

Note: All diagrams are strictly for guideline purposes only. Always consult an expert before installing the M-600 into specialized systems.

The M-600 should be serviced by qualified persons only.

## Mounting Location

Choose an area located near the chemical supply tank, chemical injection point and electrical supply. Install the pump where it can be easily serviced.

- Mount the pump to a secure surface or wall using the enclosed hardware. Wall mount to a solid surface only. Mounting to drywall with anchors is not recommended.
- Keep the outlet (discharge) tubing as short as possible. Longer tubing increases the back pressure at the pump head.

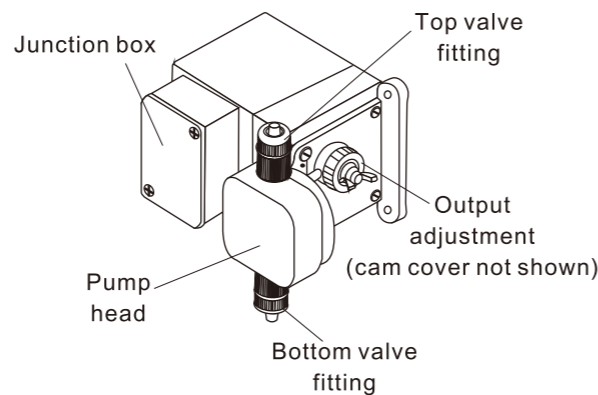

## Measuring the Pump's Output Volumetric Test.

This volumetric test will take into account individual installation factors such as line pressure, fluid viscosity, suction lift, etc. This test is the most accurate for measuring the injector's output in an individual installation.

1. Be sure the Injection Fitting and Footvalve/Strainer is clean and working properly.
2. With the injector installed under normal operating conditions, place the Footvalve/Strainer in a large graduated cylinder.
3. Fill the graduated cylinder with the solution to be injected and run the injector until all air is removed from the suction line and the solution enters the discharge tubing.
4. Refill the graduated cylinder, if necessary, and with the Footvalve completely submerged in the solution, note the amount of solution in the graduated cylinder.
5. Run the injector for a measured amount of time and note the amount of fluid injected. A longer testing time will produce more accurate results.

## How to Maintain the M-600

**CAUTION: PROPER EYE AND SKIN PROTECTION MUST BE WORN WHEN INSTALLING AND SERVICING THE M-600**

### Routine Inspection and Maintenance

The M-600 requires very little maintenance. However, the pump and all accessories should be checked regularly. This is especially important when pumping chemicals. Inspect all components for signs of leaking, swelling, cracking, discoloration or corrosion. Replace worn or damaged components immediately.

Cracking, crazing, discoloration and the like during the first week of operation are signs of severe chemical attack. If this occurs, immediately remove the chemical from the pump. Determine which parts are being attacked and replace them with parts that have been manufactured using more suitable materials. The manufacturer does not assume responsibility for damage to the pump that has been caused by chemical attack.

### How to Clean the M-600

- ✓ The M-600 will require occasional cleaning, especially the Injection fitting, the Footvalve/Strainer, and the pump head valves. The frequency will depend on the type and severity of service.
- ✓ When changing the diaphragm, the pump head chamber and pump head cover should be wiped free of any dirt and debris.
- ✓ Periodically clean the injection/check valve assembly, especially when injecting fluids that calcify such as sodium hypochlorite. These lime deposits and other build ups can clog the fitting, increase the back pressure and interfere with the check valve operation. See section FIG.4.3.
- ✓ Periodically clean the suction strainer. FIG.4.2.
- ✓ Periodically inspect the air vents located on the back of the motor compartment and under the pump head. Clean if necessary.

## How To Operate The M-600

**Adjusting the Pump Output-** The M-600 flow rate can be adjusted within a range of approximately 10%-100% of maximum output(27:1 turndown ratio) by means of a mechanical, cam type mechanism. The mechanism adjusts the pump's stroke length to 1 of 27 settings within the flow range. The pump's output is affected by the pressure of the system, the amount of suction lift, and the viscosity of the fluid being injected into the pump must be over-sized to allow for these factors. Sizing the pump to allow adjustment within the midrange is preferred to maintain accuracy. Consult the factory for individual pump model output curve data.

### To adjust the pump output:

1. Make sure the pump is off before adjusting.
2. Loosen the wing nut.
3. Turn adjusting knob so the pointer is on the desired setting. Note: pump less chemical at first, then re-adjust.
4. While holding the knob, tighten the wing nut to keep the knob at the desired setting, Note: wing nut must be tight.

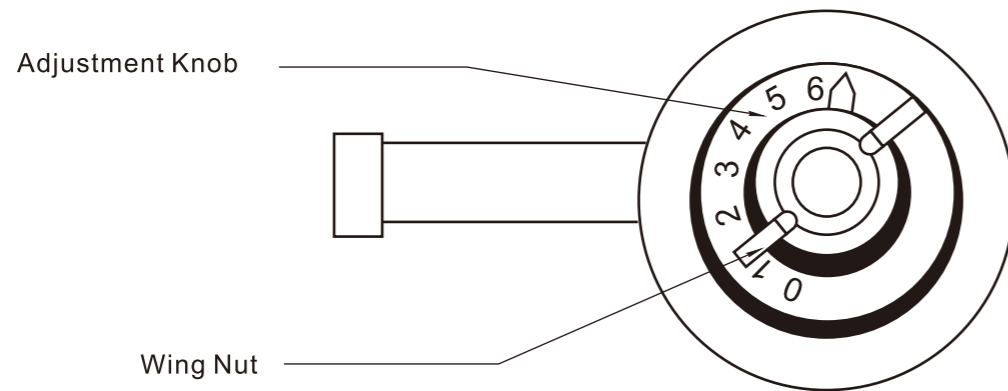

FIG.5.1 Adjustment Cam

### Priming The Pump

Each pump is factory tested with water. The test water is sealed in the pump head keeping the valves dry to aid in priming. If the valves have dried or priming is difficult due to back pressure, do the following:

1. Remove the opaque discharge tubing from the top valve fitting in the pump head.
2. Remove the top and bottom valve fittings and immerse in water to wet the valves. Reinstall the fittings.
3. With the discharge tubing removed, start the pump. Stop the pump when the fluid enters the pumphead.
4. Attach the discharge tubing to the top valve fitting.
5. Be sure the footvalve/strainer is attached to the suction tubing and is installed in a vertical position.

If your installation is at high altitude, priming may be more difficult since the atmospheric pressure is decreased. When the suction line is dry, the diaphragm may not create enough pull. If this is the case, do the following:

1. Remove the clear suction tube from the bottom valve fitting and fill completely with water.
2. While the pump is running, attach the tube (filled with water) to the bottom valve fitting.
3. When the fluid enters the pumphead, place the foot valve in the solution tank.
4. Be sure the footvalve/strainer is attached to the suction tubing and is installed in a vertical position.

- Do not mount the pump directly over your chemical container. Chemical fumes may damage the unit. Mount the pump off to the side or at a lower level than the chemical container.
- Mounting the pump lower than the chemical container will gravity feed the chemical into the pump. This flooded suction installation can reduce the time required to prime the pump. Install a shut-off valve, pinch clamp or other means to halt the gravity feed to the pump during servicing.
- Your solution tank should be sturdy. Keep the tank covered to reduce fumes.
- Be sure your installation does not constitute a cross connection with the drinking water supply. Check your local plumbing codes.

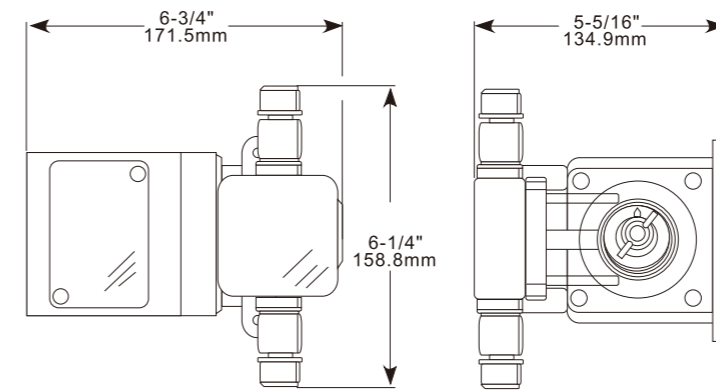
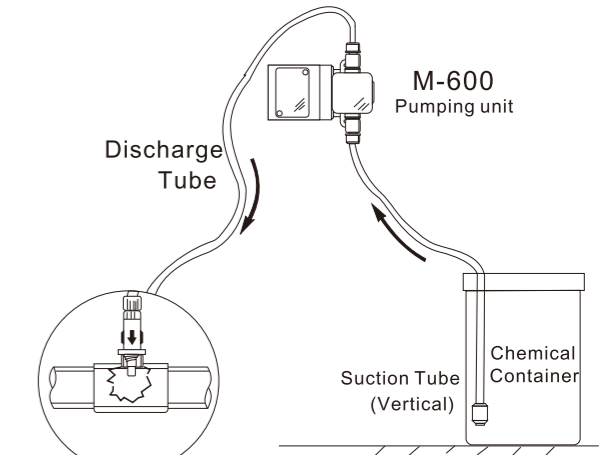

FIG.2.1 DIMENSIONAL DRAWING



1/4" & 1/2" NPT Injector

FIG.2.2 TYPICAL INSTALLATION

1. Strainer
2. Circulation Pump
3. Filter
4. Heater
5. Check Valve
6. Flowmeter
7. Injector
8. Solution Tank
9. Injection Fitting
10. Return Line

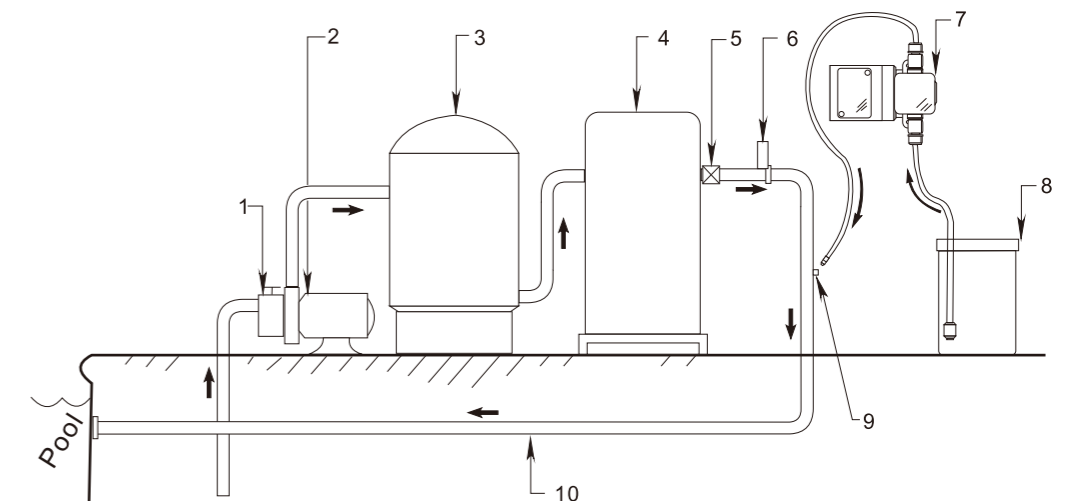
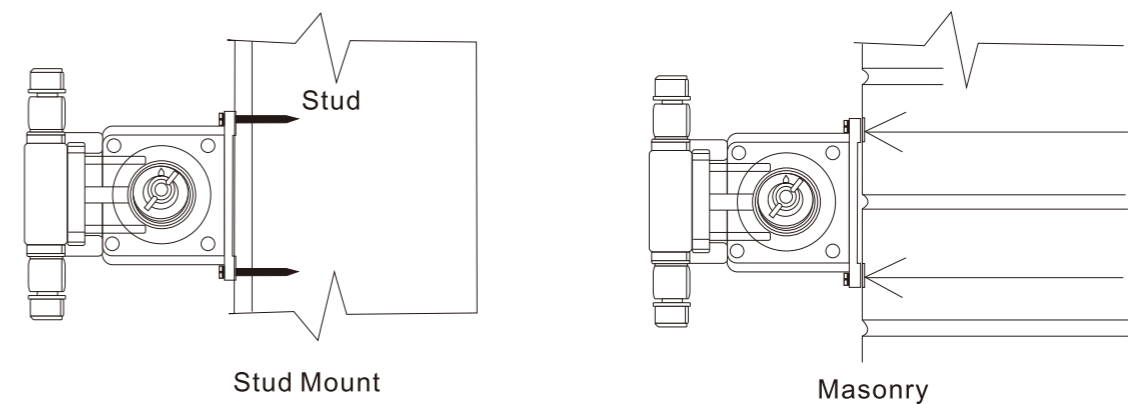

FIG.2.3 SWIMMING POOL INSTALLATION



Stud Mount

Masonry

FIG.2.4 WALL MOUNTING

## Electrical Connections

### Input Power Connections

Be certain to connect the pump to the proper supply voltage. Using the incorrect voltage will damage the pump and may result in injury. The voltage requirement is printed on the pump serial label.

**WARNING RISK OF ELECTRICAL SHOCK**

Note: When in doubt regarding your electrical installation, contact a licensed electrician. THE M-600 is supplied with a junction box for field wiring.

**JUNCTION BOX MODELS-** To reduce the risk of electric shock, be certain that a grounding conductor is connected to the green grounding screw located in the junction box.

### MOTOR LEADWIRES

INPUT VOLTAGE	HOT LEADWIRE	NEUTRAL LEADWIRE	GROUND LEADWIRE
115V 60Hz	BLACK or YELLOW*	BLUE	GREEN
220V 50Hz	BLUE or YELLOW*	BROWN	GREEN
230V 60Hz	BLACK or YELLOW*	RED	GREEN
24V 60Hz	BLUE *	WHITE	GREEN

\*Yellow leadwire: thermally protected motor

Black or Blue leadwire: standard impedance protected motor

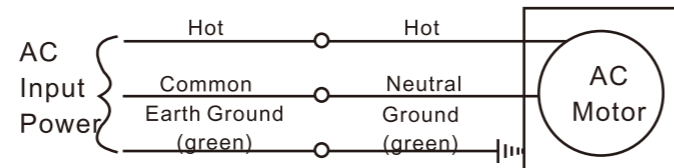
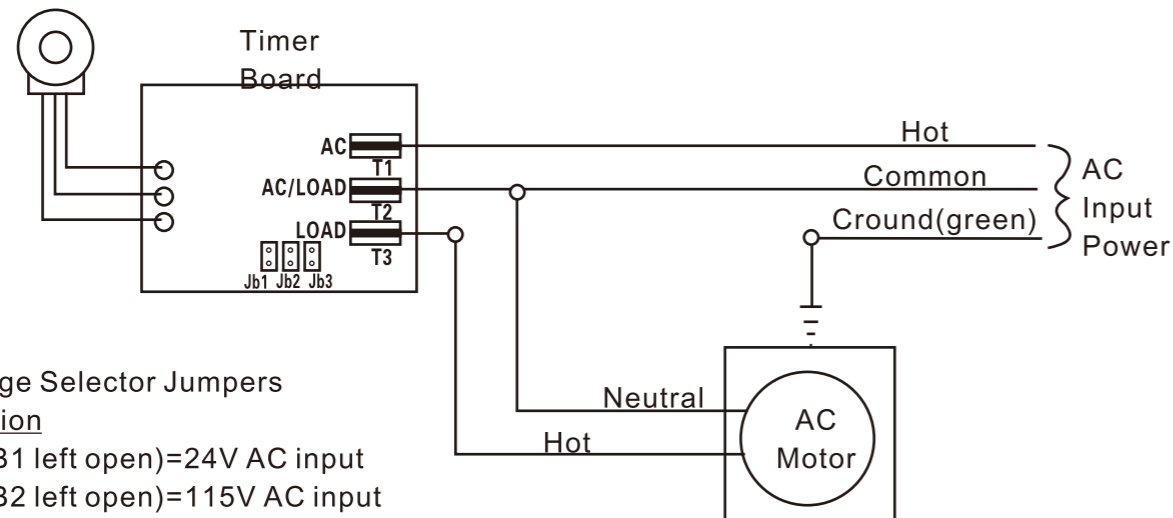

FIG.3.1 WIRING DIAGRAM-STANDARD MODELS

Cycle Adjustment Potentiometer



JB1, JB2, JB3=Voltage Selector Jumpers  
Jumpers Configuration

Install Jb2 & Jb3, (JB1 left open)=24V AC input

Install Jb1 & Jb3, (JB2 left open)=115V AC input

Remove all jumpers (JB1, JB2, & Jb3 left open)=220V, 230V AC input

FIG.3.2 WIRING DIAGRAM-FIXED TIMERS (Factory Setting)

## How To Install the Tubing and Fittings

**CAUTION: PROPER EYE AND SKIN PROTECTION MUST BE WORN WHEN INSTALLING AND SERVICING THE M-600**

**Inlet Tubing-** Locate the inlet fitting of the pump head, see Fig 4.1. Remove the tube nut. Push the clear PVC suction tubing onto the compression barb of the fitting. Use the tube nut to secure the tube. Hand Tighten only.

**Footvalve/Strainer-** Trim the inlet end of the suction tubing so that the strainer will rest in a vertical position, approximately one inch from the bottom of the solution tank. This will prevent sediment from clogging the strainer. Loss of prime may occur if the footvalve is permitted to lay on the bottom of the solution tank in a horizontal position. Slip the ceramic weight over the end of the suction tube. Press the footvalve/strainer into the end of the tube. Secure the ceramic weight to the strainer. Drop the strainer into the solution tank.

**Outlet Tubing -** Locate the outlet fitting of the pump head, see Fig 4.1. Remove the tube nut. Push the rigid outlet(discharge) tubing onto the compression barb of the fitting. Use the tube nut to secure the tube. Hand tighten only.

Trim the other end of the outlet tube leaving only enough slack to connect it to the Injection/Check valve Fitting (FIG.4.3). Increasing the length of the outlet tube increases the back pressure at the pump head, particularly when pumping viscous fluids.

Keep the inlet and outlet tubes as short as possible.

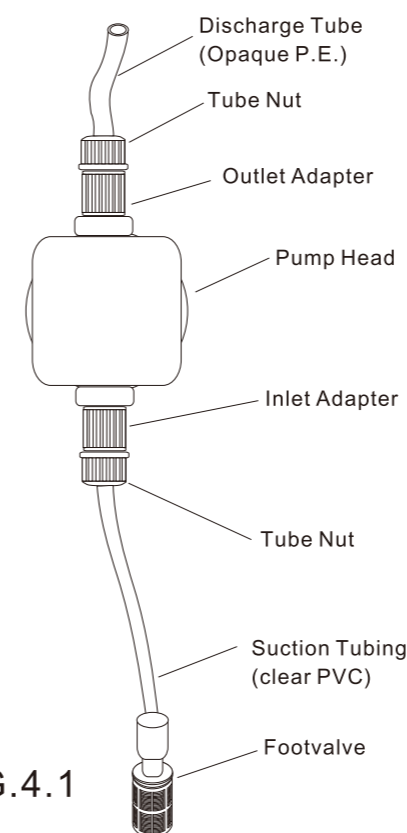

FIG.4.1

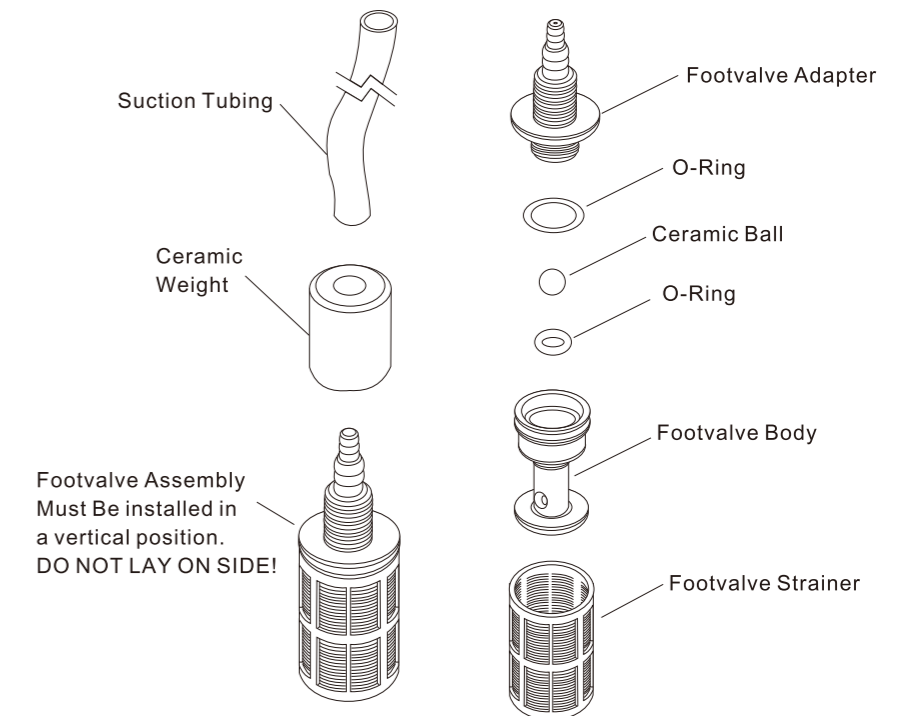

FIG.4.2 FOOTVALVE ASSY.

**Injection/Check Valve Fitting Installation-** The Injection/Check valve fitting is designed to install directly into either 1/4 or 1/2 female pipe threads. This fitting will require periodic cleaning, especially when injecting fluids that calcify such as sodium hypochlorite. These lime deposits and other build ups can clog the fitting increasing the back pressure and interfering with the check valve operation. See section 6.0.

Install the Injection/Check valve directly into the tee fitting. Do not install the fitting into a pipe stud and then into the tee. The solution must inject directly into the flow stream.

Use Teflon thread sealing tape on the pipe threads. Push the opaque outlet(discharge) tubing onto the compression barb of the Injection/Check valve fitting. Use the tube nut to secure the tube. Hand tighten only.

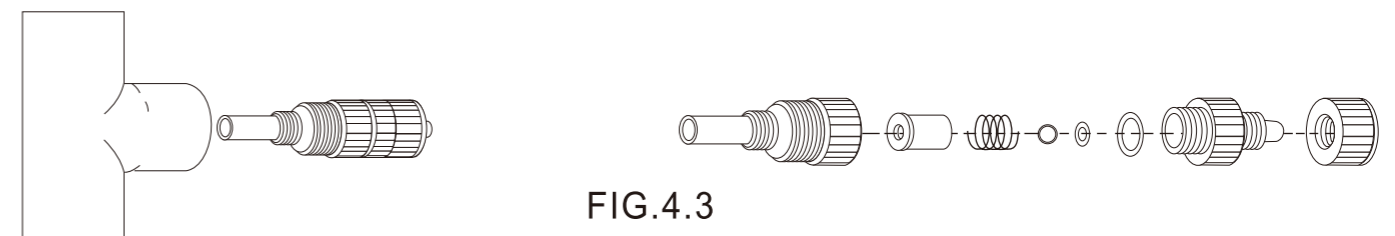

FIG.4.3  
INJECTION/CHECK VALVE  
TEE INSTALLATION AND EXPLODED VIEW